

Non-contact Laser Measuring System

OPTImess 2D - 300

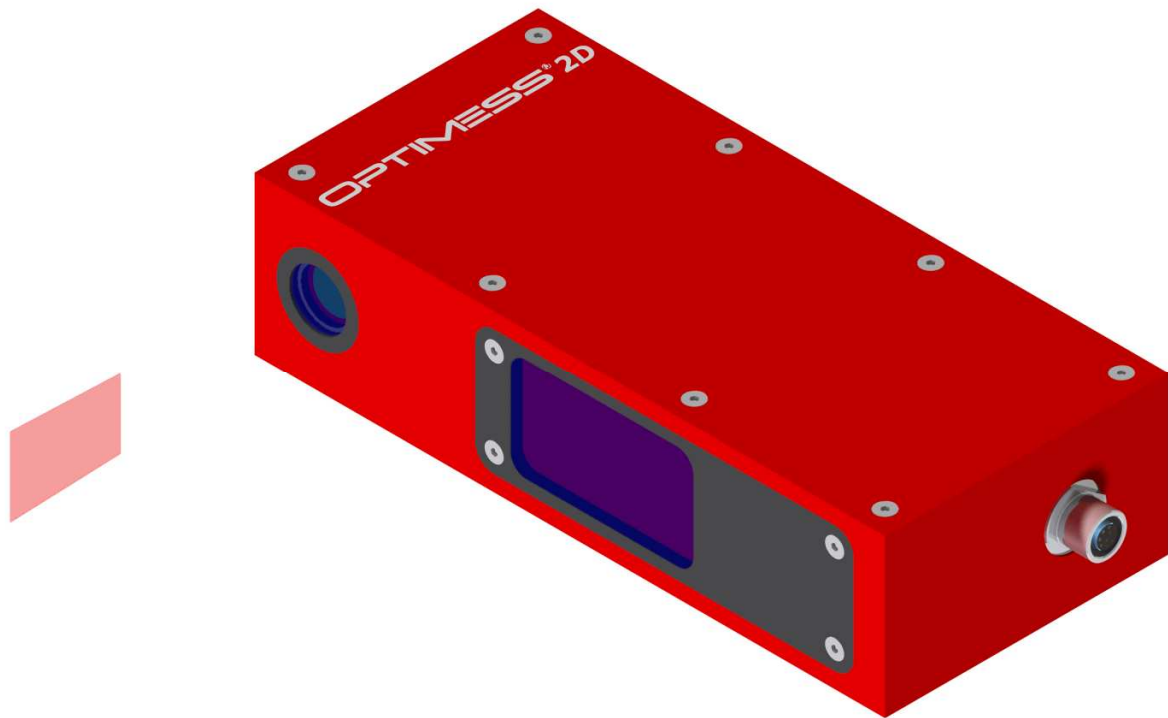

The non-contact operating, dimensional light section sensor **OPTImess 2D** is a special version of a punctiform **OPTImess** sensor.

In the **OPTImess 2D** sensor, the laser beam is projected as a line on the target by an optical system. This line is deflected to a high resolution CCD matrix by the receiver optic. The integrated controller reads out this projection and calculates X/Y c-ordinates from it. These are output on the CAN-bus interface.

By simple parameterisation with the enclosed PC software, the measuring field of the **OPTImess 2D** can be extended or limited so that an optimum ratio between the resolution and the scan frequency is always achieved. The software integrated in the measuring head enables pre-processing of the measured profile for various standard applications such as gap measurement, weld measurement, angle measurement, step and height measurement etc. The parameterisation also takes place with the enclosed PC program.

Typical applications for the **OPTImess 2D** are:

- Inspection of welds
- Profile measurements
- Geometry measurement
- Gap dimension determination
- Robot positioning and robot control

Dr. D. Wehrhahn

Meßsysteme für die Qualitätssicherung

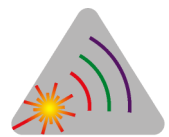

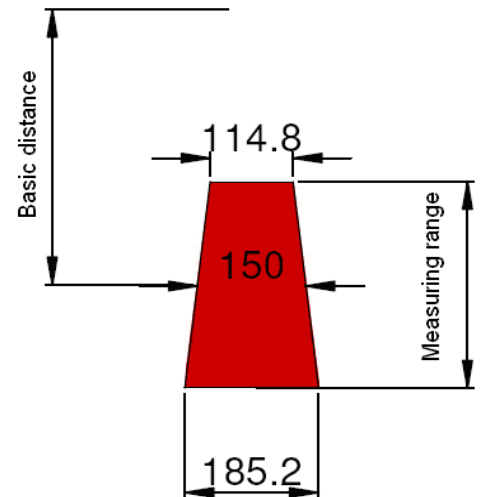
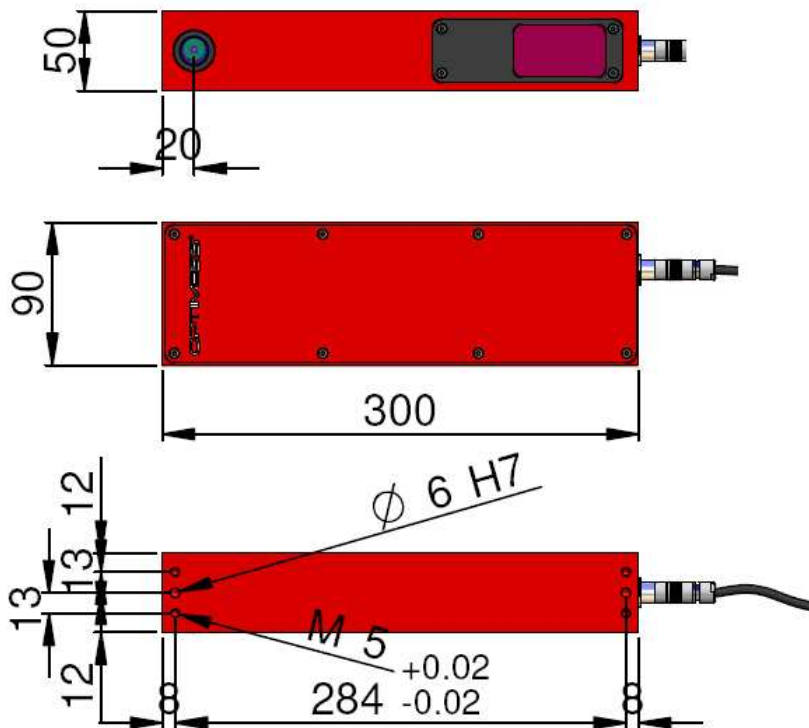

Technical data OPTImess 2D	300	Unit
Basic data		
Measuring range	300	mm
Basic distance	400	mm
Max. measuring field		
Line length start of range	114.8	mm
Line length centre of range	150	mm
Line length end of range	185.2	mm
Resolution, accuracy		
Theoretical resolution measuring range	0.067	mm
Accuracy	0.133	mm
Theoretical resolution line length	0.146	mm
Measuring frequency		
Meas. field 1280x1024 pixels (max. res.)	27	Hz
Meas. field 500x500 pixels	120	Hz
Meas. field 100x100 pixels	3000	Hz

The technical data above refer to measurement on white, diffusely reflecting surfaces.
The laser protection class can be specified with 2M, 3R or 3B. This is given by the respective application and is determined mainly by the surface to be measured and the implemented measuring frequency.

Dr. D. Wehrhahn
 Meßsysteme für die Qualitätssicherung
 Dr. D. Wehrhahn
 Meßsysteme für die Qualitätssicherung
 Hildesheimer Str. 140
 D-30173 Hannover

Fon +49 511 51 26 65
Fax +49 511 52 21 52

Mail info@drwehrhahn.de
Web www.drwehrhahn.de